

Karel Skipala  
Automatization of production processes, machine control modernization, production of  
industrial electronics  
<http://www.skipala.cz>

# USER MANUAL FOR DIGITAL REGULATOR

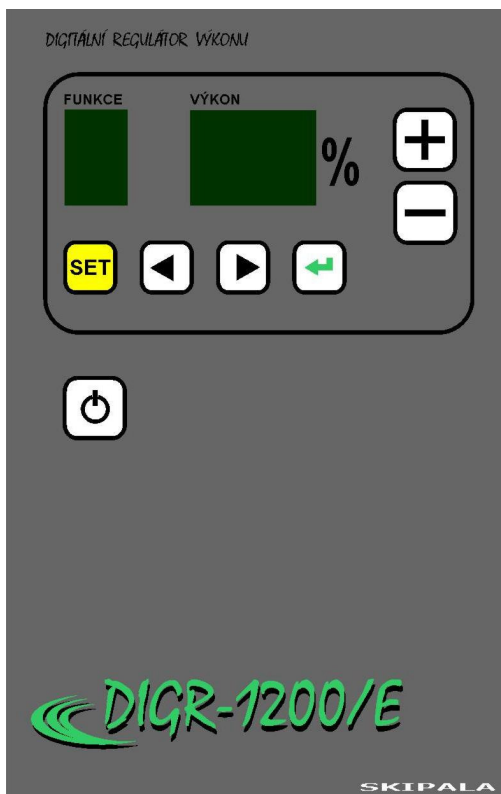

Version: 1.8  
January 2008

## 1. Technical properties

Supply voltage	230V AC/50Hz
Maximal output current	8A
Coverage	IP54
Working temperature	10–55°C (50–130°F)
Power dissipation	10W
Suppression of interference	EN 55011/B
Short circuit proof	1.5kA
Dimensions	130x185x65 (WxHxD)
Weight	1.2kg

## 2. Generally

Regulator DIGR1200/E is intended to power regulation of vibration feeders driven by electromagnetic coil. Regulator's main component is triac, which is switched with phase shift. Regulator enables step setting of frequency: 100Hz, 50Hz, 33Hz, 25Hz, and 20Hz. The intensity of oscillations can be set from range 20–99%. Function of regulator is programmed from control panel by user. Regulator can be controlled from control panel or by external analog or digital signals.

Small dimensions and effective user functions create preconditions for using these regulators (working alone or with superior system PLC) in most applications of vibration feeders.

## 3. Before connection

Check up the regulator. Be sure it hasn't been damaged by transport. In the case of damage contact the supplier.

If you see dewiness, wait for it's evaporating.

## 4. Installation

Regulator can be mounted in horizontal or vertical position with outlets down.

Drill holes to the main board, where the regulator should be attached (pic.1), and make screw thread M4. Attach the regulator with 4 screws M4x8.

pic.1 - holes for attaching

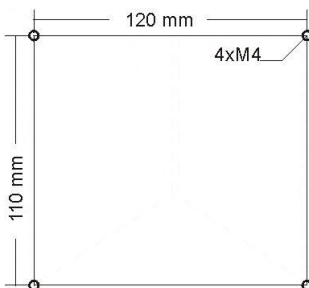

## 5. Connection

Only persons with adequate electrotechnical qualification are allowed to connect the regulator.

**Warning! Connect only when disconnected from power network.**

Unscrew four screws M3 attaching the cover (pic.2) and remove it.

pic.2 - dismantling the cover

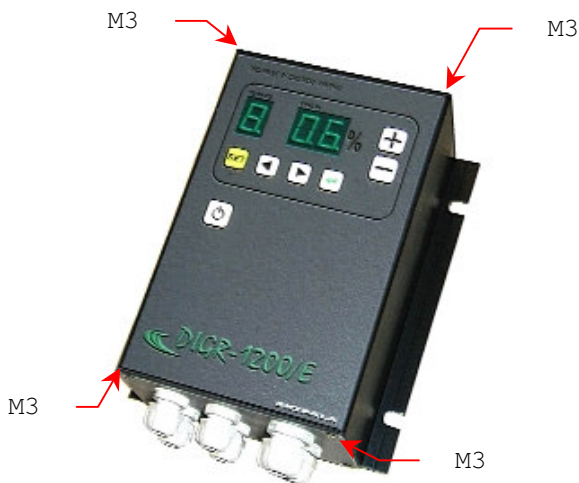

Terminal clamps are placed under this cover (pic.3).

pic.3 - terminal clamps

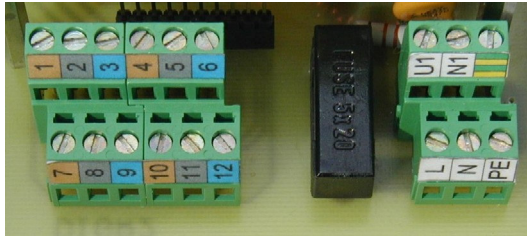

Make connection according to pic.4. If the supply cable does not suit you, dismount it and connect clamps **L,N,PE** with voltage 230V through cable H03VV-F3Cx1mm<sup>2</sup> or fungible. Connect coil of vibration feeder with clamps U1,N1 and protective clamp marked by green-yellow combination.

Connect sensors and digital or analog signals according to demands of current application (pic.4). For advanced explanation see chapter 8 - Functions description. Sensors are powered by safely separate voltage 24V DC, current drain of both sensors must not exceed 50mA. Prefer sensors of PNP type (output signal is attached to +24V). If you use sensors NPN, it's necessary to put a 3.3k $\Omega$  resistor between supply clamp +24V and signal.

After your finishing the connection mount back the cover and connect the regulator to the power network. Status when the regulator is under voltage, but isn't switched-on, is signalled on display by turning on the decimal point.

pic.4 - outer connection of regulator

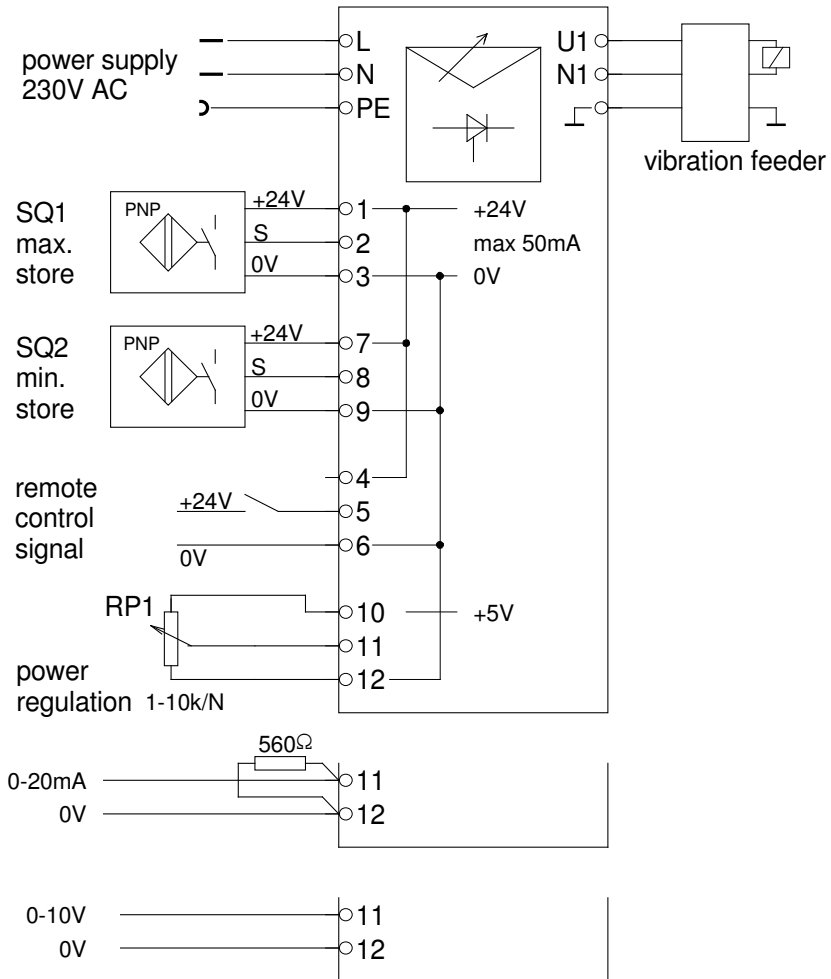

## 6. Switching-on

There are three ways how to switch on the regulator:







I. Push the button on/off .

For switching off push the button again.

II. Switching-on by remote control: Signal change on clamp no.5 from 0V to +24V causes switching-on the regulator. Signal change on clamp no.5 from +24V to 0V causes switching-off the regulator.

III. The regulator will automatically switch on after connection of power supply. For this switching-on set function no.5 to value 01. This type of switching-on is possible only when the regulator is controlled by superior controlling system. However this setting is not suitable as START - STOP of regulator because there is a min. 3s time-out between switching-off and switching-on. If this time-out is not kept the regulator may get blocked. In that case you must do restart (see chapter 9). Connect signal START-STOP with clamps no.2 (+24V) and no.3 (0V) (see pic.4).

## 7. Setting

Switch on the regulator and press button . The number of function and its value will be shown on the display. Set the number of required function by buttons  . Set the value of function by buttons  . After setting all values press button  which will save these values into memory. If you want to leave setting without saving press button . If you are not in setting mode you can set only value of function no.0. - required power. Regulator can't save the change of value when running. Save will be done after changing state to STOP or when the regulator is switched off by button on/off or by remote control signal. **Warning!** If the regulator is RUN mode and you switch it off by disconnecting it from power network, the value of function no.0 won't be saved into memory.

The meaning of functions and their values is described in chapter 8 and in table pic.5.

## 8. Functions description

### Function no.0 - required power

The regulator regulates power in maximal range 20-99% with step 0.5%. Value 0.5% is expressed by turning on the decimal point. The range of required power is limited by values of function no.6 - minimal power and no.7 - maximal power.

### Function no.1 - sensors

Regulator can work according to the needs of concrete application without sensors, with one sensor or with two sensors. Signals from sensors set the regulator to STOP or RUN mode. Status STOP is signalled by turning on the decimal point at number showing the number of function. The influence of sensors depends on value of function no.1:

- 00- Sensors are not connected. The feeder is constantly in RUN mode after switching-on.
- 01- One sensor is connected: SQ1 - maximal store. If the sensor is active (there's +24V on clamp no.2) the feeder is in STOP mode. In other case the feeder is in RUN mode. The change from STOP to RUN mode and otherwise is done with a time-out set by value of function no.2 and no.3 (see down).
- 02- Two sensors are connected: SQ1 and SQ2. If sensor SQ2 is not active (there's 0V on clamp no.8) regulator is in RUN mode. If both sensor SQ1 and SQ2 are active (there's +24V on clamps no.8 and no.2) regulator is in STOP mode. The change from STOP to RUN mode and otherwise is done with a time-out set by value of function no.2 and no.3 (see down).
- 03- One sensor is connected: SQ1 - maximal store. Its behaviour is inverse to value 01. If the sensor is not active (there's 0V on clamp no.2) the feeder is in STOP mode. In other case the feeder is in RUN mode. The change from STOP to RUN mode and otherwise is done with a time-out set by value of function no.2 and no.3 (see down). If you start the regulator by superior controlling

system PLC, use this setting. Connect the START signal with clamp no.2.

- 04- Two sensors are connected: SQ1 and SQ2. Their behaviour is inverse to value 02. If sensor SQ2 is active (there's +24V on clamp no.8) regulator is in RUN mode. If both sensors (SQ1 and SQ2) are not active (there's 0V on clamps no.8 and no.2) regulator is in STOP mode. The change from STOP to RUN mode and otherwise is done with a time-out set by value of function no.2 and no.3 (see down).

#### Function no.2 - time-out when changing to RUN mode



Regulator is in STOP or RUN mode according to the information from sensors. The change from STOP to RUN mode is done with a time-out. This time-out is expressed by value 0 - 99 which means 0 - 9.9s.

#### Function no.3 - time-out when changing to STOP mode

Regulator is in STOP or RUN mode according to the information from sensors. The change from RUN to STOP mode is done with a time-out. This time-out is expressed by value 0 - 99 which means 0 - 9.9s.

#### Function no.4 - regulation method

The value of function no.4 determines the way how the required power is set.

00- Power is set by buttons  .

01- Power is set by voltage signal 0-5V on clamp no.11. This setting is suitable for using the potentiometer. Value of the potentiometer must be from range 1-10kΩ.

02- Power is set by voltage signal 0-10V or by current signal 0-20mA on clamp no.11. If you use current signal it's necessary to put a 560Ω resistor between clamp no.11 and clamp no.12.

#### Function no.5 - automatic switching-on

00- Automatic switching-on is blocked

01- The regulator will be automatically switched on after connection of supply voltage.



#### Function no.6 - minimal power

Low limit of regulation is set by value of this function. Minimal value is 20, maximal value is 10 units lower than the value of maximal power (function no.7).

#### Function no.7 - maximal power

High limit of regulation is set by value of this function. Minimal value is 10 units higher than the value of minimal power (function no.6), maximal value is 99.

#### Function no.8 - oscillations frequency

The range for frequency of oscillations is 20-100Hz. The gist of frequency change consists in skipping a certain count of sinusoid half-waves of regulated voltage. Its result is a discontinuous "jump" change. The range of this function is 0 - 4 that means frequency 100-20Hz (see table pic.5).

#### Function no.9 - run-up, run-out

In some cases it is desirable to run-up and run-out the feeder continuously. You can set the speed of run-up and run-out ramp by setting this value from range 0-5. Value 5 means time 5s for run-up from 0% to 100%.

### **9. Maintenance**

Regulator doesn't require any special maintenance. In case of failure do not do any repairs and send the regulator to the manufacturer. A permissible faint power oscillation can occur when the regulator works. This is caused by interference from supply network.

If the regulator doesn't work properly you can do the restart that sets all functions to default. To restart the regulator disconnect it from power network, press the button SET, connect the regulator to the power network and finally release the SET button.

pic.5 - Functions table

<b>function no.</b>	<b>value</b>	<b>description</b>
0 power	20-99	required power (20-99%)
1 sensors	00	no sensors
	01	one sensor, log.1 switches off
	02	two sensors, log.1 switches off
	03	one sensor, log.0 switches off
	04	two sensors, log.0 switches off
2 RUN time-out	00-99	time-out when switching from status STOP to RUN (0 - 9.9s)
3 STOP time-out	00-99	time-out when switching from status RUN to STOP (0 - 9.9s)
4 control	00	power is set by control panel
	01	power is set by potentiometer RP1
	02	power is set by signal 0-10V or 0-20mA
5 switching-on	00	automatic switching-on blocked
	01	automatic switching-on allowed
6 min. power	20-89	minimal power limitation (20-89%)
7 max. power	30-99	maximal power limitation (30-99%)
8 oscillations frequency	00	100 Hz
	01	50 Hz
	02	33 Hz
	03	25 Hz
	04	20 Hz
9 run-up	0-5	time of run-up and run-out ramp (0-5s from 0% to 100%)

pic.6 - control panel description

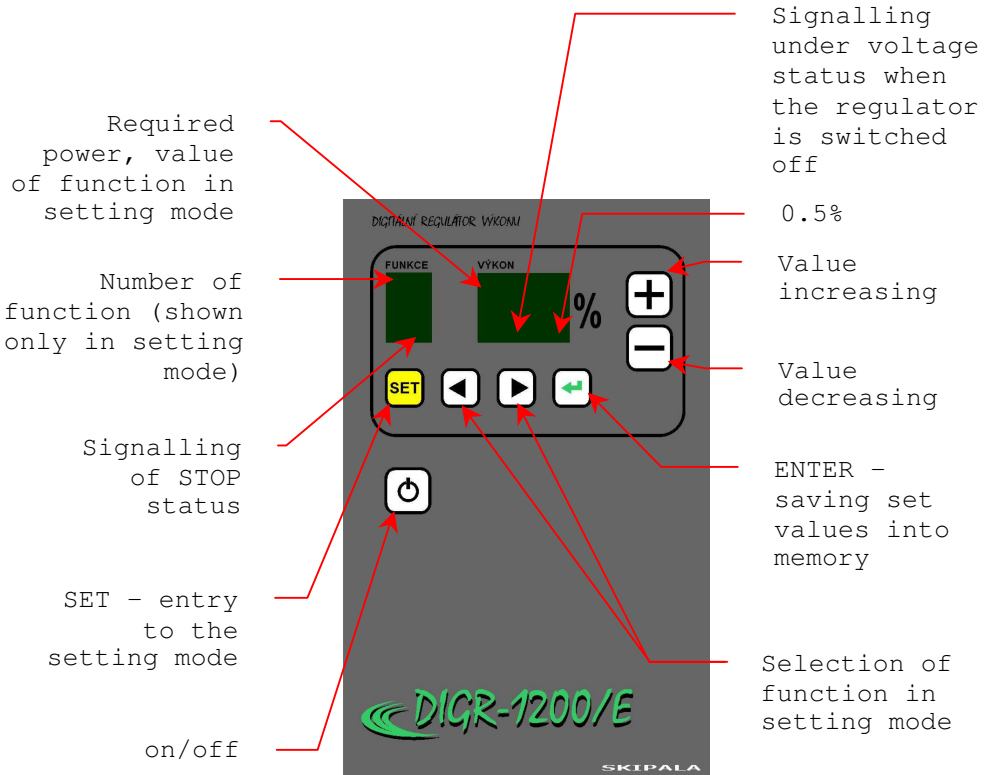

## 10. **Manufacturer's declaration**

Manufacturer declares that the product corresponds to all requirements consequent on decree of the government no. 17/2003 Sb. and no. 18/2003 Sb. about technical requirements on products in full wording. Ground for this declaration is certificate of Electrotechnical testing institute no.1060967.

This product is safe under condition of usual using and conditions noticed in this manual.

## 11. **Warranty**

We provide you a 12 months warranty since the day of sale.

Serial number:

Dealer:

Date of sale:

## 12. **Manufacturer**

Production and service by:

**Karel Skipala**

Rybník 162

560 02 Česká Třebová

Czech Republic

tel.: 00420 465 533 410

e-mail: karel@skipala.cz

<http://www.skipala.cz>