

# USER MANUAL FOR DIGR-2200/D CONTROLLER



## CONTENTS

1. Technical data.....	3
2. Description .....	3
3. Connection .....	7
4. Operating status .....	10
5. Activation .....	10
6. R-run / S-stop .....	10
7. Setting and saving parameters .....	11
8. Description of parameters .....	11
9. Maintenance .....	21
10. Disposal .....	21
11. Guarantee .....	21
12. ES Declaration of conformity .....	22

## 1. Technical data

Supply voltage $U_{\text{nap}}$	230V 50Hz
Maximum output current	6A (sum drive A+B)
Output voltage	2x 20-99% $U_{\text{nap}}$
2x digital input	24V DC PNP
2x digital output	24V DC max. 120 mA
1x analogue input	0-10V DC
or digital input	24V DC PNP
Auxiliary output voltage	24V DC max. 180 mA
	10V DC max. 10 mA
Coverage	IP54
Working temperature	10-55°C
Loss output	10 W
Interference suppression	EN 55011/A
Short-circuit resistance	1.5 kA
Weight	1.2 kg

## 2. Description

The DIGR-2200/D Controller is a double triac controller for regulating two vibration feeders, drive A and drive B, driven by an electro-magnetic coil. The basic regulation value is the output voltage. The controller can be used for quickly setting the oscillations frequency 100 Hz, 50 Hz, 33 Hz. The controller is controlled by 28 parameters set by the user on the control panel. The controller can be controlled from the control panel by outside analogue and digital signals.

The controller has IP54 coverage and can be mounted outside the switchboard. It includes a safe separated 24V / 4VA DC supply for the sensors and valves and a 10V DC supply for analogue input.

Their small size and easy use allow the controllers to work independently, as well as with a master system in most feeder applications.

Fig. 1 - description of the controls

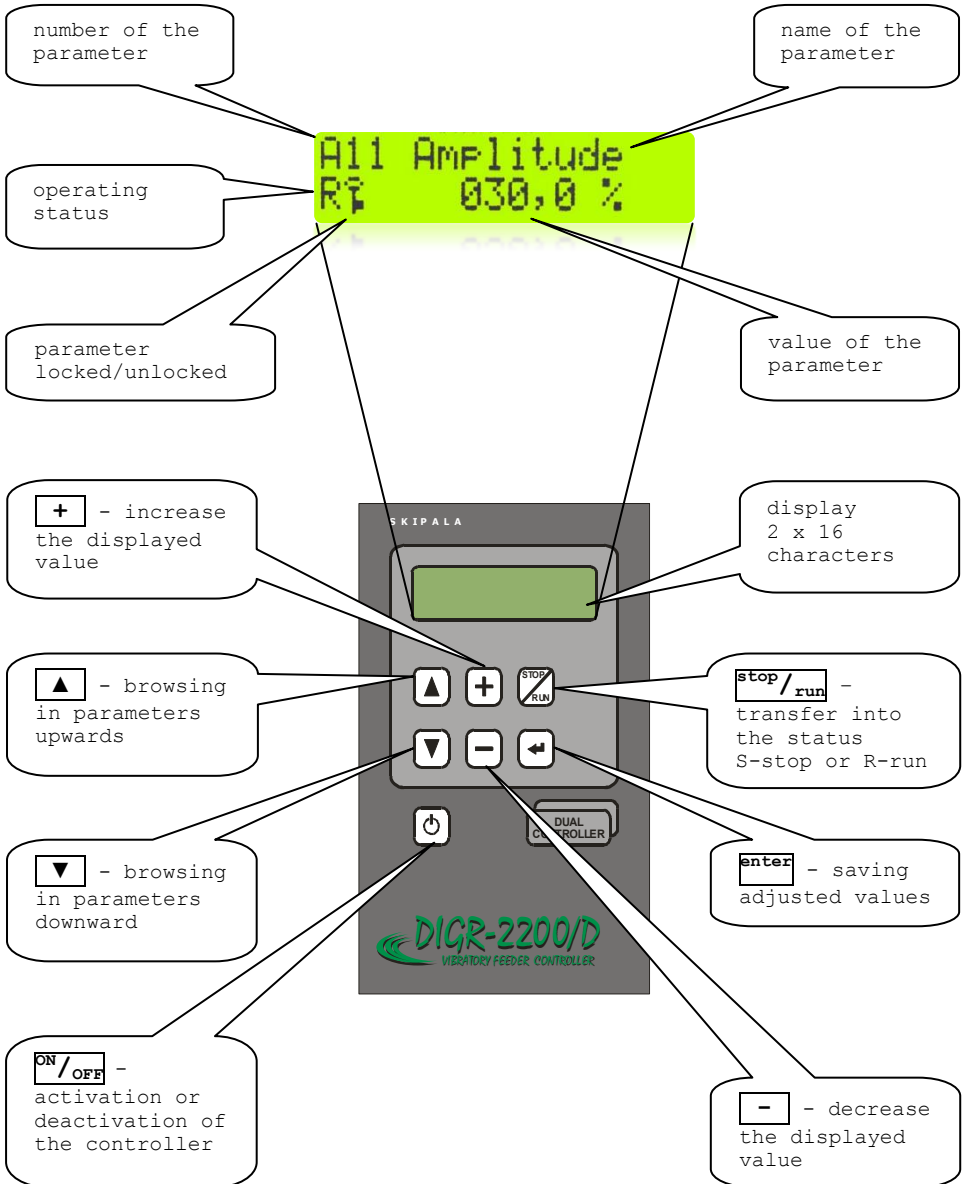

Fig. 2 - basic dimensions

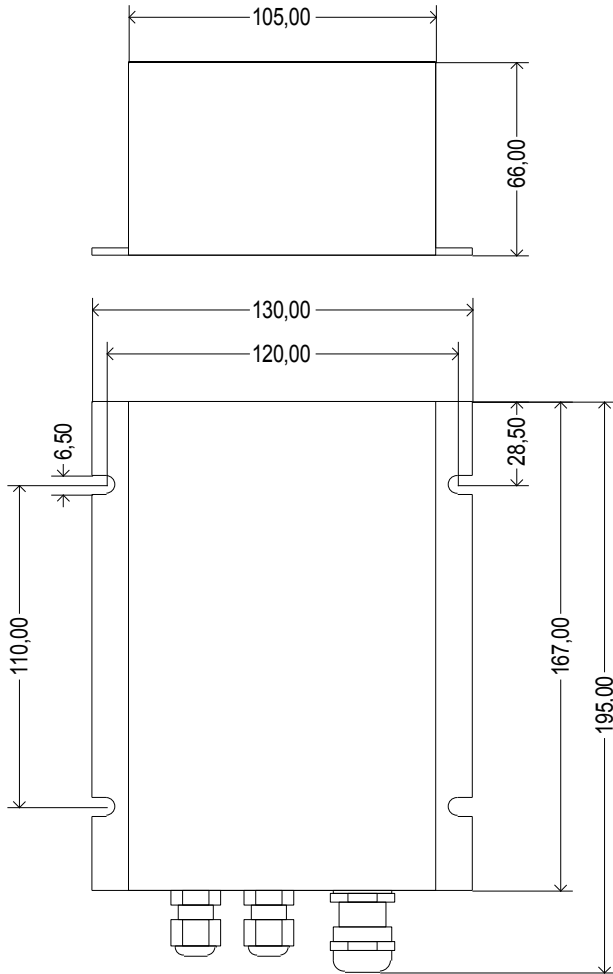
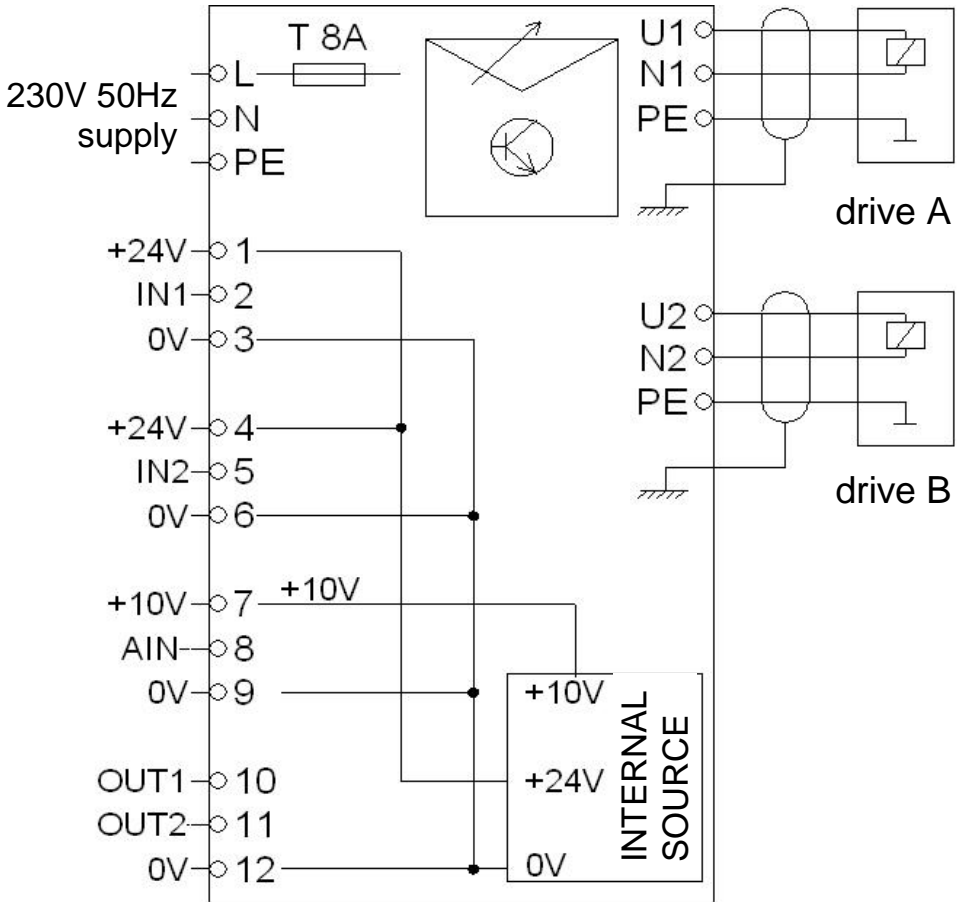

Fig. 3 - connecting the external part of the controller



### 3. Connection

The external electric parts of the controller must only be connected by someone with the proper electrotechnical qualification. Only connect if the controller is disconnected from the network

#### 3.1. Assembly

The controller can be installed horizontally or vertically with the outlets downwards.

It must be mounted on a firm part of the equipment without direct vibrations.

Drill 4 x 4.2 mm diameter holes with M5 threads into the base plate on which the controller is mounted. Fig. 2 shows the spans of the holes. Clamp the controller with 4 M5 x 8 bolts with fan washers.

**⊗ Attention!** Washers are needed so when tightened the layer of elox is cut and the controller is conductively joined to the body of the machine.

#### 3.2. Dismantling of the cap

Unscrew four bolts M3 fixing the cap of the controller and remove it (Fig. 4).

Fig. 4 - dismantling of the cap

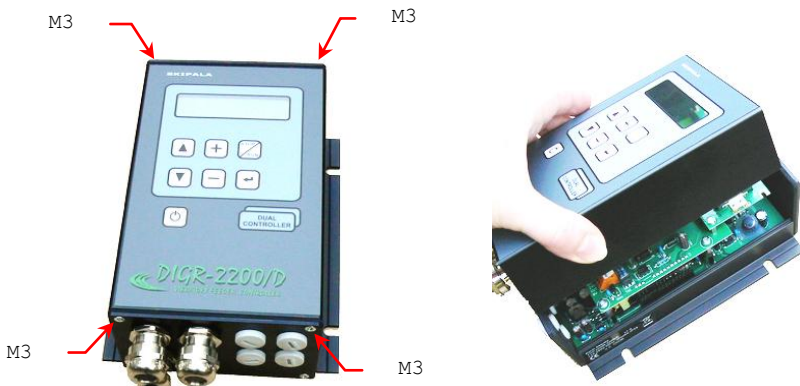

For easier access to the terminal box, we recommend dismantling parts with forged pieces (Fig. 5).

Fig. 5 - dismantling parts with outlets

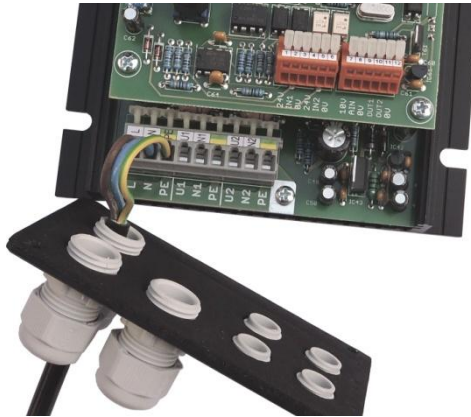

The connecting terminals are under this cap (Fig. 6).

Fig. 6 - connecting terminals

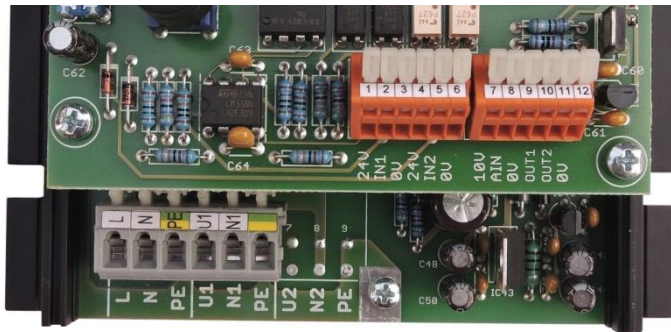

### 3.3. Connecting the power part

The controller has an internal T8A circuit breaker, which protects the device against short circuits, not against overloading! Select the series protection according to the actual value of the connected loading. If more generators are connected to the equipment, these controllers should be connected to various phase conductors because of current peak.



Connect according to *Fig. 3*. If the cable to the coil is longer than 1.5 m, we recommend connecting with a shielded cable. The shielding is terminated by the metal outlet.

The termination of power cables is shown in *Fig. 7*. The cross-sections of conductors is as follows:

Cross-section of conductors	0.5 - 1.5 mm <sup>2</sup>
Cable diameter	8 - 10 mm

**⚠ Attention!** The protective conductor must be at least 15 mm longer than the other conductors.

*Fig. 7 - termination of power cables*



*Fig. 8 - connecting conductors to terminals*

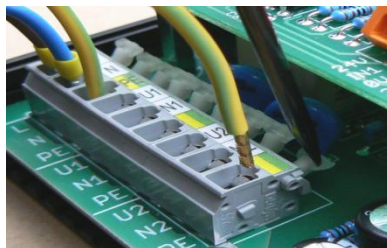

### 3.4. Connecting the control part

Cross-section of conductors	0.08 - 0.5 mm <sup>2</sup>
Diameter of the cable	3 - 6.5 mm

Connect sensors, digital and analogue signals according to the requirements of the specific application, according to *Fig. 3*. Sensors are connected by a safe separate 24V DC voltage. Use PNP sensors (the output signal is switched to +24V).

### 3.5. Re-mounting the cap

After finishing the outside part of controller, remount the part with outlets and the upper cap. Only then can the supply voltage be switched on.

#### 4. Operating status

The operating status is displayed as the first character of the lower line (*Fig. 1*):

- ⚡ The controller is under voltage, all activities are disconnected. **⚠ Attention!** The inside circuits of the controller are under voltage!
- S** STOP - The controller is connected in the S-stop status. The output power voltage is blocked, drives A,B are inactive. All parameters can be browsed and edited and parameters saved in the memory.
- R** RUN - Selected drive A or B, is connected, the status is R-run. The output voltage is connected, the drive vibrates. All parameters can be browsed and edited.
- W** WAIT - The controller is connected, the selected drive, A or B, is in the W-wait status. The output power voltage is blocked, the drive is inactive. The controller waits for a signal from the sensors or from the master control system. All parameters can be browsed and edited.

#### 5. Activation

The controller can be activated in two ways which are determined by setting parameter A36 (B36) (Chapter 8.23.):

- a) Activated by pressing the **ON/OFF** button (*Fig. 1*). Disconnected by re-pressing the button. This way of connecting and disconnecting is recommended if the controller is operating independently, without links to other electric equipment.
- b) Automatic connection after the supply voltage is connected. Set the A36 (B36) parameter to "automatic". This way of connecting is recommended if the controller is supplied through a switching device (e.g. disconnecting switch, contactor) from the master electric equipment.

#### 6. R-run / S-stop

Pressing the **stop/run** button switches the controller into the S-stop status, feeders A and B are inactive. Re-pressing the button switches the controller from the S-stop status to the R-run status, or W-wait.

## 7. Setting and saving parameters

The number of parameter is shown on the display, the first line on the left (*Fig. 1*) The initial letter shows which set is displayed. The set is changed by the parameter A10 (B10) (Chapter 8.1.).

Use  and  buttons to browse the required parameter. If it is not locked (key symbol), the value of the parameter can be changed using the  or  button. First, locked parameters must be unlocked by typing the password, parameter A38 (B38) (Chapter 8.25.). Press the  button to save, all parameters are saved in the memory at once. It is recommended to save in the S-stop status.

## 8. Description of parameters

The controller contains a set of parameters for drive A and a set of parameters for drive B. The following description of the parameters for drive A also analogically applies to drive B.

### 8.1. A10 (B10) Selecting the drive

The set of parameters for drive A and the set drive B can be selected.  The set of parameters can be selected at any time by pressing  and  buttons at the same time.

### 8.2. A11 (B11) Amplitude

Setting the value of the output voltage and the intensity of vibrations of the feeder from 20-100% with 0.5% steps. The setting range can be restricted by the value of parameters A17, A18 (Chapter 8.6.). The buttons cannot be used for setting if the amplitude is typed by AIN analogue signal (Chapter 8.11.).

### 8.3. A12 (B12) Timeout ON A13 (B13) Timeout OFF

The parameters sense if at least one sensor is connected to the controller monitoring the filling of the output storage tank of the feeder. We recommend setting parameters to 0 s.

If the controller is in the W-wait status parts are taken from the storage and their movement causes a short interruption of the signal from the filling sensor. The Timeout ON (parameter A12) must be longer

than the interruption of the signal. Then the interruption will be ignored and the controller switches into the R-run status after the storage tank is discharged. The same occurs after the storage tank is filled. Individual parts pass around the sensor and create short impulses. The Timeout OFF (parameter A13) must be longer than these impulses. Then they will be ignored and the controller switches into the W-wait status after the actual filling of the magazine. The parameters can be set from 0-25 s.

#### **8.4. A14 (B14) Starting time**

This parameter can be used when starting and running down the feeder to change the value of the amplitude so that the feeder starts to run fluently. The setting range is 0-6 s. The time relates to starting from 0% to 100% and running down from 100% to 0%.

#### **8.5. A15 (B15) Batch ON A16 (B16) Batch OFF**

In some cases, the feeder, e.g. pre-storage tank, needs to work with interruptions, in batches. Use parameter A15 to set the time during which the batch is supplied, parameter A16 the time of the pause between batches.

#### **8.6. A17 (B17) Amplitude, maximum limit A18 (B18) Amplitude, minimum limit**

Use these parameters to restrict the amplitude setting in parameter A11 (B11).

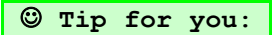
 **Tip for you:** The operators can correct the value within the permitted range without greatly affecting the correct work of the feeder.

#### **8.7. A19 (B19) Input IN1**

Determining the use of digital input IN1.

**Not connected** - The input is not used or is only monitored and its state is transferred to the output (Chapter 8.12).

**Start** - The +24V signal must be supplied so that the feeder can be activated. If the remaining conditions are fulfilled as well (according to the configuration for additional inputs), then

upon supply of the 24V signal the feeder will be in the R-run status. Otherwise, the feeder is in the W-wait status. Switching from the W to R status and vice versa is immediate, the parameters A12, A13 do not affect this.

 **Tip for you:** Use this setting if the feeder is controlled from a master control system.

**Maximum reserve** - The sensor is connected to the input monitoring the maximum reserve in the storage tank being filled by the feeder. If the sensor is active during the period stated by the parameter A13, the feeder is stopped and switched to the W-wait status. Returning to the R-run status depends on whether the second input is defined as the minimum reserve. If so, the feeder is activated according to the status of this sensor (see below). The feeder is switched to the R-run status after the maximum reserve sensor is not active for the time stated by the parameter A12.

 **Tip for you:** By setting parameters A12, A13 properly only one sensor is sufficient for monitoring the storage tank.

**Minimum reserve** - This setting is only used if the second output is defined as the maximum reserve. The sensor monitoring the minimum in the storage tank is connected to the input being filled by the feeder. The feeder is switched to the R-run status after the minimum reserve sensor is not active for the time stated in parameter A12. If both reserve sensors are active for the time in parameter A13 activity stops.

**Ejector** - The input controls the ejector together with the digital output OUT1, OUT2 (Chapter 8.12.).

### 8.8. A20 (B20) Type of sensor 1

Type of sensor connected to input IN1.

**Switching NO** - 24V is on the output of the sensor if the supplied part is present.

**Disconnecting NC** - 24V is on the output of the sensor if the supplied part is not present.

### 8.9. A21 (B21) Input IN2

Determining the use of digital input IN2. The setting is identical as for input IN1 (Chapter 8.7.).

### 8.10. A22 (B22) Type of sensor 2

Determining the type of the sensor connected to input IN2. The setting is identical as for input IN1 (Chapter 8.8.).

### 8.11. A23 (B23) Analogue AIN

Determining the use of analogue input AIN. It can be configured as analogue 0-10V, or digital 0/24V.

**Connected** - The input is not used.

**Amplitude** - The input is configured as analogue. The 0-10V voltage is used to set the amplitude and intensity of vibrations of the feeder from 20-100% with 0.5% steps. The setting range can be restricted by parameters A17, A18. The set value is displayed in parameter A11.

**JOG-min** - The input is configured as digital. 24V signal on the input causes the amplitude to switch to the minimum value, which is determined by parameter A18. ☺ **Tip for you:** Use this setting if you need to decrease the speed of the feeder during the activity. For example, when pouring material on the scale when approaching the desired weight.

**Start** - The input is configured as digital. The supply of the +24V signal is the condition for the feeder to be activated. ☺ **Tip for you:** Use this setting if you need to control the feeder from the master control system and digital inputs IN1, IN2 are occupied by the connected sensors.

**Stop** - The input is configured as digital. The supply of the +24V signal causes the controller to stop.

### 8.12. A24 (B24) Output OUT1

Determining the use of digital output OUT1.

☺ **Tip for you:** A pneumatic valve which controls the air jets, switches or ejectors, for example, can be connected to the digital output. The master control system PLC can be used as the signal, or as the signal if the controllers are connected in a cascade.

**Not connected** - The input is not used.

**Drive in running** - Output is always switched when the drive is in the R-run status.

**Air** - The output controls the air supply valve into the feeder. The valve is switched on before activation of the feeder. The time is set using parameter A25 (Timer T11). When the feeder is turned off, the air is turned off with a delay, which is set using parameter A26 (Timer T12).

**Ejector E1** (Fig. 9a) - The output is connected to the valve controlling the ejector i.e. equipment removing incorrectly oriented or redundant parts from the route of the feeder. One of the inputs, e.g. IN2, must be set to the ejector function (Chapter 8.9.). The sensor is connected to the input reading the parts. Use Timer T11 (parameter A25) batch ON to set the timeout so that the ejector does not respond to short impulses from the sensor. Use Timer T12 (parameter A26) batch OFF to change the ejection time.

*Fig. 9a - activity of the ejector E1*

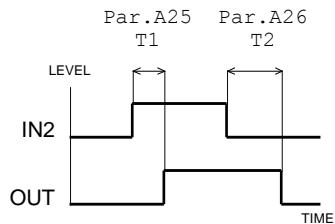

**Ejector E2** (Fig. 9b) - is similar to the ejector E1, except that it uses three timers. Timer T11 (parameter A25) suppresses short impulses at the input IN2. Timer T13 (parameter A27) determines the delay between the signal IN2 and switching output OUT. Timer T12 (parameter A26) determines the length of switching output OUT. Ejector E2 is good for example for detecting the stuck parts. If parts are not passing under the sensor for time T13 (parameter A27) the output OUT is switched, which is connected to the valve that controls air nozzles, which blow off stuck parts from the feeder track.

Fig. 9b - activity of the ejector E2

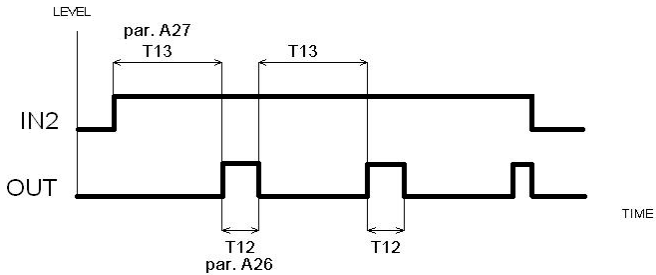

**Monitor IN1 ON** - The output monitors the activated status of digital input IN1. This is only monitored when the drive is in the status RUN - operating. If during the period set by parameter A27 (Timer T13), there is signal 24V on input IN1, the output OUT switches on. The signal on the monitored input can be protected from short impulses, which are caused by the movement of parts under the sensor. Impulses from status 0 to status 1 are suppressed by setting parameter A25 (Timer T11). Impulses from status 1 into status 0 are suppressed by setting parameter A26 (Timer T12). All impulses which are shorter than the set time, will be ignored.

☺ **Tip for you:** This setting can be used, for example, if connecting the signalling beacon on the input, to signal the shortage of components in the magazine.

**Monitor IN1 OFF** - The output monitors the off status of digital input IN1. The setting and functions are the same as when monitoring input IN1 ON.

**Monitor IN2 ON** - The output monitors the on status of digital input IN2. The setting and functions are the same as when monitoring input IN1 ON.

**Monitor IN2 OFF** - The output monitors the off status of digital input IN2. The setting and functions are the same as when monitoring input IN1 ON.



### **8.13. A25 (B25) Timer T11**

Universal timer where the use is determined by setting parameter A24 (Output OUT1).

### **8.14. A26 (B26) Timer T12**

Universal timer where the use is determined by setting parameter A24 (output OUT1).

### **8.15. A27 (B27) Timer T13**

Universal timer where the use is determined by setting parameter A24 (Output OUT1).

### **8.16. A28 (B28) Output OUT2**

Determining the use of digital output OUT2. The setup is similar to the parameter A24 (output OUT1). The difference is in the numbers (marks) of the timers, that are utilized by the output. Instead of timers T11, T12, T13 (parameters A25, A26, A27) uses output OUT2 timers T21, T22, T23 (parameters A29, A30, A31).

### **8.17. A29 (B29) Timer T21**

Universal timer where the use is determined by setting parameter A28 (Output OUT2).

### **8.18. A30 (B30) Timer T22**

Universal timer where the use is determined by setting parameter A28 (Output OUT2).

### **8.19. A31 (B31) Timer T23**

Universal timer where the use is determined by setting parameter A28 (Output OUT2).

### **8.20. A32, A33 (B32, B33)**

Reserved for future use.

### **8.21. A34 (B34) Frequency**

The oscillations frequency is changed by omitting a certain number of half-waves of the controlled voltage sine curve. Therefore the change is not fluent, but in steps. The value of the frequency parameter can be set to 100 Hz, 50 Hz, 33 Hz.

**8.22. A35 (B35) Connection A+B**

States the connection between drive A and drive B.

**Separately** - Drives A and B work independently.

**In cascade** - Drive A is superior to drive B. If A is stopped, B is automatically stopped.

**8.23. A36 (B36) Activation**

States how the controller behaves after connecting the supply voltage.

**Using the button** - After connecting the supply voltage, the controller is off. It is activated by pressing the button  ON / OFF.

**Automatically** - After connecting the supply voltage the controller is automatically activated. This setting does not exclude activation and deactivation by pressing. The setting is valid for both drives.

**8.24. A37 (B37) Service functions**

For servicing.

**Not used** - Service functions are not activated.

**Accidental stop** - When testing the feeder actual operational behaviour can be simulated. The feeder is disconnected and connected at irregular intervals. The setting is valid for both drives.

**8.25. A38 (B38) Password**

Typing the password temporarily unlocks blocked parameters.

The password is delivered by the firm as a 3-digit number 108 and can not be changed. Its purpose is to protect the controller against accidental overwriting of locked parameters. The password cannot be typed if it is changed or the controller disconnected. The setting is valid for both drives.

**8.26. A39 (B39) Locking**

Use this parameter to lock or unlock the editing of parameters A11 - A16 (B11 - B16). First, type the password by parameter A38 (Chapter 8.25.). Then, using the  + or  - button set the number of the parameter

to be locked or unlocked. Press the  button. The key icon appears after the parameter number. This means that the selected parameter is locked. It can be unlocked in the same way. By pressing the  button the key icon disappears and the parameter is unlocked. Parameters are locked if the password is disabled.

### **8.27. A40 (B40) Language**

Language selection.

**English** - Always available.

**Czech** - Is delivered if another language version has not been ordered. As standard Russian or German can be ordered or another language agreed on.

### **8.28. A41 (B41) Information**

For more information about this product, visit our Internet pages <http://www.skipala.cz>

### **8.29. Factory settings**

If there are complications with controller, RESTART it to reset the factory settings of all parameters. RESTART as follows:

- Disconnect the controller from the supply network and wait at least 10 seconds to discharge condensers.
- press the  button and hold it down
- connect the controller to the supply network
- release the  button

The parameter values of the factory settings are given in the table (*Fig. 10*).

Fig. 10 - parameters table

<b>number of parameter</b>	<b>factory values drive A (B)</b>	<b>values of application drive A</b>	<b>values of application drive B</b>
10 Drive select.	A		
11 Amplitude	34,00%		
12 Timeout ON	00.0s		
13 Timeout OFF	00.0s		
14 Starting time	01.0s		
15 Batch ON	00.0s		
16 Batch OFF	00.0s		
17 Ampl. MAX	100%		
18 Ampl. MIN	20%		
19 Input IN1	not connect.		
20 Sensor 1 type	NO		
21 Input IN2	not connect.		
22 Sensor 2 type	NO		
23 Analogue AIN	not connect.		
24 Output OUT1	not connect.		
25 Timer T11	00.0s		
26 Timer T12	00.0s		
27 Timer T13	000s		
28 Output OUT2	not connect.		
29 Timer T21	00.0s		
30 Timer T22	00.0s		
31 Timer T23	000s		
34 Frequency	50Hz		
35 Connect. A+B	separate		
36 Activation	by button		
37 Service fnc	not used		
38 Password	0		
39 Locking			
40 Language	english		
41 Info	info		

## 9. Maintenance

The controller does not require any special maintenance. Carry out Pergorm only regular inspection in accordance with ČSN 33 2000-1, ČSN 34 3100 and Regulation No. 50/78 Sb. In the case of failure do not repair - send the controller to the manufacturer for repair.

 **Tip for you:** In the case of complications with the operation of the controller, reset the factory setting of the parameters (Chapter 8.29.).

## 10. Disposal

At the end of its service life the controller must be handed over for professional disposal to a specialized firm or the manufacturer.

## 11. Guarantee

The guarantee for the product is 12 months from the day of sale.

Serial number:

Seller:

Date of sale:

## 12. ES DECLARATION OF CONFORMITY

In accordance with Act No. 22/97 Coll. on the technical requirements for products, as effective amended by act.

Manufacturer: **Karel Skipala**

Rybník 162, 560 02 Česká Třebová  
Czech Republic  
Reg. No.: 48608017  
<http://www.skipala.cz>

Identification of the product:

Name: Digital power controller  
Model: **DIGR-2200/D**

We declare that the above-mentioned product fulfils the respective provisions of the following EU regulations:

Government Directive No. 17/2003 Coll. (Directive of the European Parliament and the Council 2006/95/EC)  
Government Directive No. 616/2006 Sb. (Directive of the European Parliament and the Council 2004/108/EC)

Description of the product: The product is designed for regulating vibration feeders driven by an electromagnetic coil.

List of technical and harmonized standards used:

ČSN EN 61010-1 ed.2:11 čl. 5, 5.1, 5.1.2, 5.1.3, 5.1.4, 5.1.5.2, 5.1.7, 5.3, 5.4, 6, 6.1, 6.2.2, 6.4, 6.5.2, 6.5.2.3, 6.5.2.5, 6.5.3, 6.7, 6.9.2, 6.7.1.2, 6.7.1.3, 6.8.2, 6.8.3.1, 8.2, 8.2.1, 8.2.2, 8.3, 8.3.1, 10.5.2, 10.5.3;  
ČSN EN 60695-2-11:01; ČSN EN 61326-1 ed.2:13

Source materials for issuing the EC Declaration of Conformity: **Certificate No. 1150486** issued on 02.07.2015 by the Electro-technical testing institute, certified body No. 3018.

The two last digits of the year in which the CE indication was attached to the product: 15

In Rybník dated 02.07.2015

Karel Skipala  
Company owner

